

UCP-822A SERIES

Electropneumatic Transducer

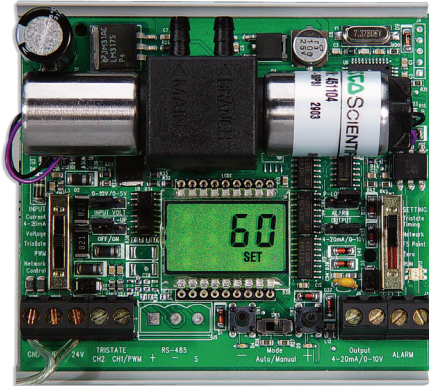

Installer's Specifications

Power Supply	22-30VDC, 20-30VAC, 47-63 Hz, 150mA max. average, 350mA peak
Control Input	4-20mA, (0-10V, 0-5V; jumper selectable), Tri-State, PWM
Input Impedance	4-20mA, 250Ω; 0-5/0-10V, 10kΩ
Manual Override	Digital pushbutton adjust, switch-selectable mode
Alarm Contact	100mA@30VAC/DC (pressure loss, manual mode, jumper selectable)
Accuracy	1% F.S.; combined linearity, hysteresis, repeatability @20°C ambient
Operational Temp. Range	41° to 140°F (5°C to 60°C)
Temp Coefficient	±0.1%/°C
Operating Environment	10-90% RH, non-condensing -4°C to 60°C
SCIM	523 in ³ /min@45 psi; 8520 cm ³ /min@310.3 kPa; 333 in ³ /min@20 psi; 5407 cm ³ /min@137.9 kPa
Supply Pressure	Minimum: 0.1 psi plus user F.S. pressure; maximum: 45 psig
Control Range	User programmable zero selectable from 0-25psi; Full Scale 0-25psi
Pressure Differential	0.1 psig (supply to branch)
Pressure Indication	Electronic, 3-1/2 digit LCD back-lite
Minimum Tubing Length	15-feet
Port Connection	1/8 i.d. poly tubing
Media Connection	Clean dry air or inert gas. Not for use with oxygen service or combustible gases



NOTICE

- This product is not intended for life or safety applications.
- Do not install this product in hazardous or classified locations.
- Read and understand the instructions before installing this product.
- Turn off all power supplying equipment before working on it.
- The installer is responsible for conformance to all applicable codes.

PRODUCT IDENTIFICATION

<p>UCP-822A-</p> <p>Output</p> <div style="border: 1px solid black; width: 20px; height: 20px; margin: 0 auto;"></div> <p>Blank = None AO = Analog output</p>	<p>Alarm</p> <div style="border: 1px solid black; padding: 2px; width: 20px; height: 20px; margin: 0 auto; text-align: center;">PL</div> <p>= Pressure Loss Alarm or Manual Mode Alarm</p>	<p>Option</p> <div style="border: 1px solid black; width: 20px; height: 20px; margin: 0 auto;"></div> <p>Blank = None VPF = Vent on power failure</p>
---	---	--

DIMENSIONS

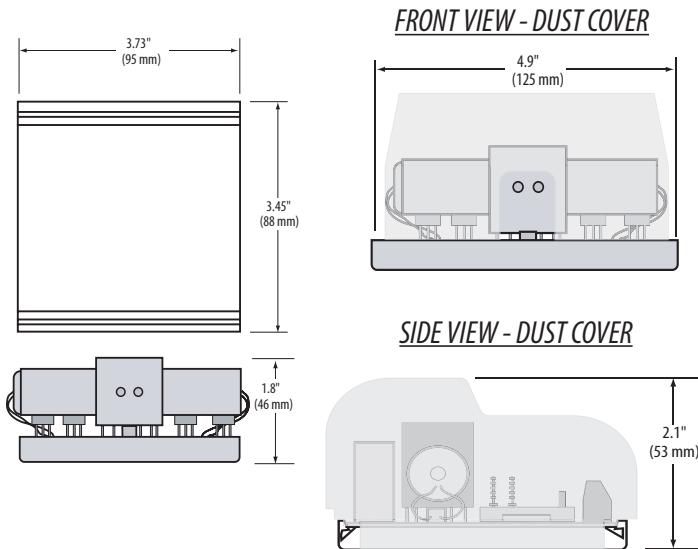

QUICK INSTALL



Observe handling precautions for static sensitive devices to avoid damage to the circuitry which would not be covered under the factory warranty.

1. Mount transducer using screws provided. Take care to avoid damaging electronic components.
2. Configure jumpers for desired operation as shown (page 2).
3. Wire transducer as shown in wiring diagram (page 3).
4. Attach pressure tubing to hose barb. Observe MAIN and BRANCH port labels. Use flexible 1/8" i.d. poly tubing for main and branch pneumatic connections. **Main supply pressure must not exceed 45 psig.**

CONFIGURATION

INPUT: User selectable current (4-20mA) or voltage (0-5/0-10V), Tri-state, PWM

OUTPUT STANDARD: 0-20 psig

OUTPUT OPTION: 4-20mA or 0-10V (feedback status for branch pressure)

SETTINGS: User programmable Tristate Timing—travel time

- Min. = 1 second
- Max. = 600 seconds
- Default = 60 seconds

PWM

- Min. pulse setting = 0.01-0.60 seconds
- Max. pulse setting = 1.0 to 75.0 seconds
- Full Scale (FS) scale point user programmable 0-25psi
- Zero user programmable 0-25psig

After desired settings have been selected, move slide switch to the RUN position

MODE: Auto for normal operation or Manual to adjust pressure

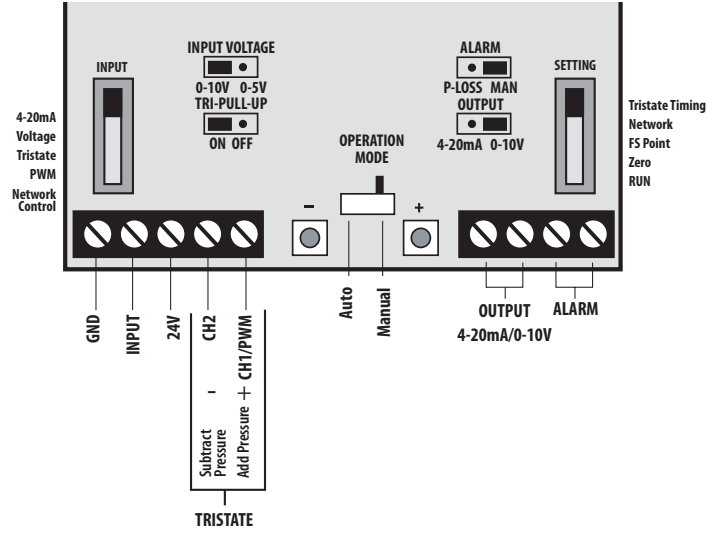

WIRING

Current/Voltage Control, Voltage Output Example

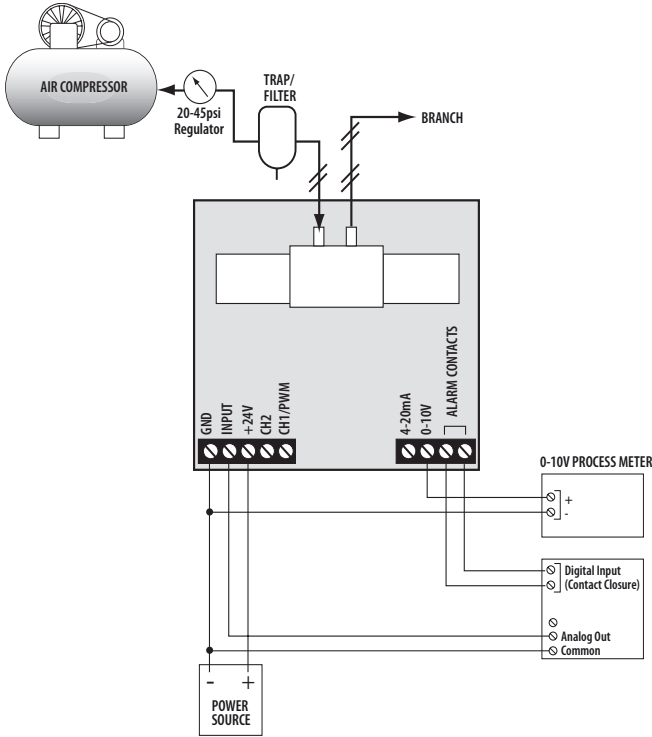

- Input switch set to voltage (0-5VDC or 0-10VDC)
- Input volt jumper set to either 0-5VDC or 0-10VDC
- Input switch set to 4-20mA
- Output jumper set to 0-10VDC

Current/Voltage Control, Current Output Example

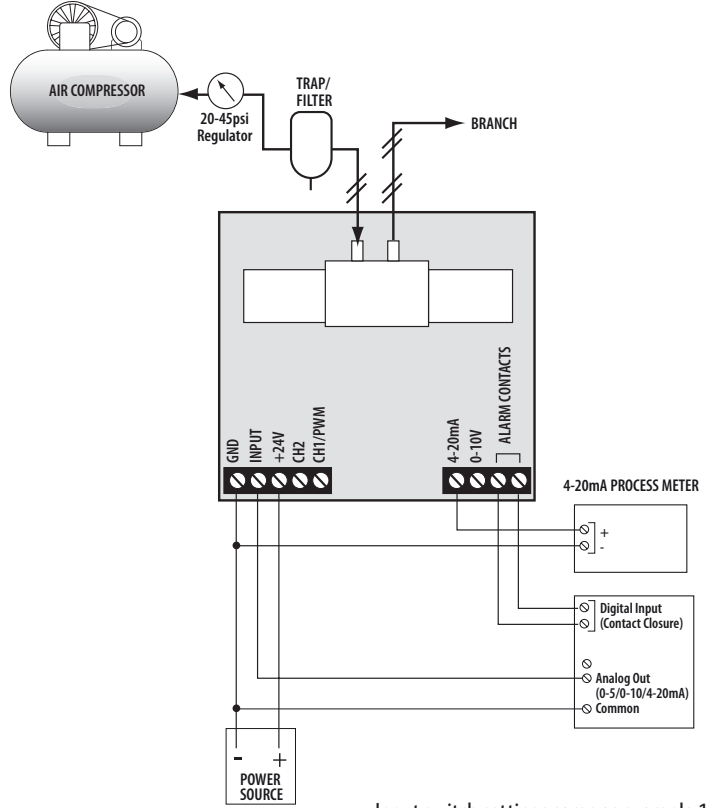

- Input switch settings same as example 1
- Output jumper set to 4-20mA

PWM Control Example

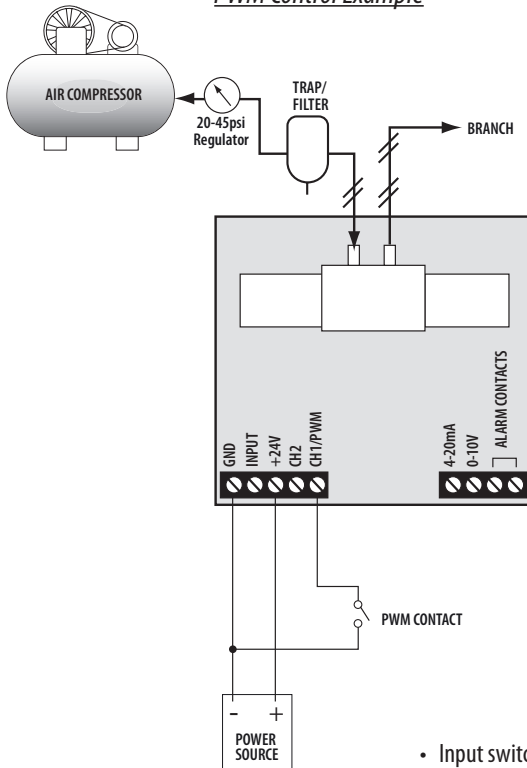

- Input switch set to "PWM"
- Tri-State jumper set to "ON"

Tri-state Control Example

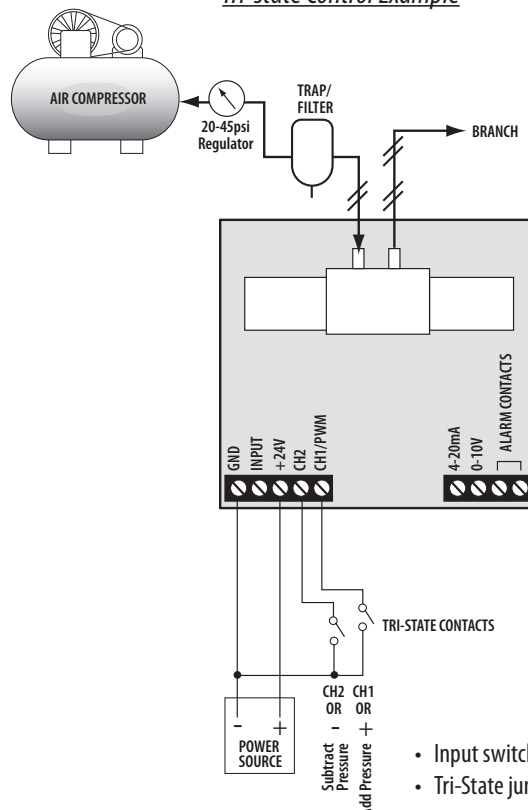

- Input switch set to "TRI-STATE"
- Tri-State jumper set to "ON"

SPECIAL INSTRUCTIONS

PWM Mode

To ensure correct operation when using the tristate or PWM modes, use the tristate pullup.

To set the minimum pulse value, adjust the Setting and Input switches as shown:

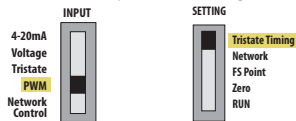

"LO" will momentarily appear on the LCD, indicating that the minimum pulse width is being set. Use the (+) and (-) buttons to increase or decrease this value. To set the maximum pulse width, push both buttons simultaneously. "HI" will momentarily appear, indicating that the maximum pulse width is being set. Push both buttons to cycle between the "HI" and "LO" settings. Return the Setting slide switch to RUN to save these settings.

If the controller receives a pulse that is shorter than the minimum pulse width, the output will go to 0% of the range set with the zero and span settings. If the controller sees a pulse that is the same or longer than the maximum pulse width, the output will go to 100% of the range selected with the zero and span settings.

In this example the minimum pulse width is set to 0.60s, the maximum is set to 10s, zero is set to 0, and span is set to 10psi. Assume the controller receives a pulse of 5s duration:

$$\text{Pulse range} = 10s - 0.60s = 9.4s$$

$$\text{Pressure range} = \text{span} - \text{zero} = 10 - 0 = 10$$

$$\text{Output} = (5 / 9.4) \times 10 = 5.3 \text{ psi}$$

Tristate Mode

To ensure correct operation when using the tristate or PWM modes, use the tristate pullup.

Travelttime is defined as the contact closure time required to go from zero to full scale. If travelttime is set to 10 seconds and the TRISTATE 1 input is connected to ground for 5 seconds, the output will be 50%. If the input is connected to ground for another 5 seconds, the output will be 100%. If TRISTATE 2 (the decreasing input) is grounded for 10 seconds, the products output will return to 0%.

To set the travel time, adjust the Setting and Input switches as shown:

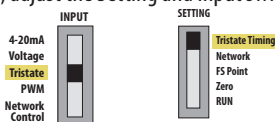

Press the (+) or (-) buttons to increase or decrease the travel time. Minimum travel time is 5 seconds; maximum is 600 seconds. Return the Setting switch to RUN to save all settings. The device's internal counters measure the contact closure time with 100Hz resolution.

Note: If Tristate input is to be operated by a triac output, use an AC relay to provide a dry contact closure to the UCP-822A input.

Tubing Length

Minimum tubing length is 15ft or an equivalent volume of 2.2 cubic inches. Shorter tubing lengths can cause the unit to oscillate.

Analog Output

The output is generated from the branch pressure. It is calculated as follows:

FS = Full Scale Point

Zero = Zero setting

In volt mode:

$$\text{Pressure} = (10 / (\text{FS} - \text{Zero})) * \text{Voltage} + \text{Zero}$$

$$\text{Voltage} = (\text{Pressure} - \text{Zero}) / (\text{FS} - \text{Zero}) * 10$$

In current mode:

$$\text{Pressure} = (\text{FS} - \text{Zero}) * ((\text{Current} - 4) / 16) + \text{Zero}$$

$$\text{Current (in mA)} = ((\text{Pressure} - \text{Zero}) / (\text{FS} - \text{Zero})) * 16 + 4$$

Examples:

Zero setting = 5 psi; Span = 20 psi; Branch pressure = 16 psi

Volt mode: Voltage = ((16 - 5) / (20 - 5)) * 10 = 7.33 V

Current mode: Current = ((16 - 5) / (20 - 5)) * 16 + 4 = 15.73 mA

Alarms

Alarm contacts are closed in normal operation (auto mode setting).

Alarm Contact: Contacts open when no power is applied or when the device is in an alarm state.

Manual Mode Alarm: Contacts are open in manual mode setting. Contacts will then close for normal operation. Move the P-LOSS/MAN jumper to the manual mode setting. You do not need to power cycle the product after moving jumpers or the Auto/Manual switch.

Pressure Loss Alarm: Contacts open when the branch pressure falls and stays below 20% of the desired pressure for a period of 2 minutes.

FS Point and Zero Setting

To set the Zero or FS point, move the SETTING slide switch from Run to Zero or FS point setting, respectively.

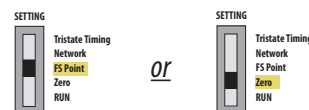

The 'Set' icon will appear on the LCD. Using the (+) and (-) buttons add or decrease the pressure setpoints.

Blink Codes

Slow green	Normal operation
Slow green with one fast red	Manual mode alarm (contacts open)
Slow green with two fast reds	Pressure loss alarm active (contacts open)
Slow red	SETTINGS slide switch not in RUN position
Two fast reds	Slide switch not in RUN position and Alarm (contacts open)
Three fast reds	Over-voltage or over-current fault
Four fast reds	Over pressure on branch side; over 25 psi